

Thermal Drive Actuator RL 605D23, 2 x AC 24...230 V

RL 605D23

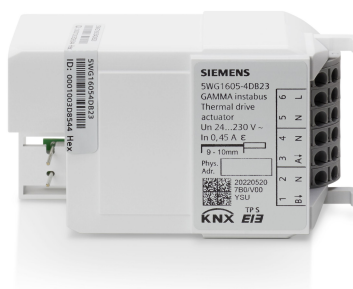

The thermal drive actuators are used for controlling electro-thermal actuators for heating or cooling systems.

- 2 semiconductor outputs for noiseless control of AC 24 V or AC 230 V actuators
- Maintenance-free terminals for connecting and looping through solid, stranded and fine-stranded conductors
- Built-in device for installation in an automation module box AP 118 or room automation module box AP 641, which has to be ordered separately

Functions for configuration with ETS:

- With priority control of security and override functions
- Automatic or demand-based or manual valve flushing
- Extensive, internal room temperature controllers and ventilation controllers (which can be assigned freely or for each channel)
- Powerful calculator modules for weighting temperature values or determining the largest or a weighted control value
- Interaction with primary systems for heating demand or cooling demand requirements and demand-based pump control

Characteristics

The thermal drive actuator is used to control electro-thermal actuators in water-based heating or cooling systems. It is used in building automation. Device control is conducted via KNX.

The thermal drive actuator features 2 semiconductor outputs. These can be used to silently control several AC 230 V or AC 24 V actuators per channel or device according to their power consumption.

The actuator controls both de-energized closed and de-energized open actuators.

In addition, the thermal drive actuator contains 2 internal room temperature controllers, matching the number of valve outputs. These can be internally assigned directly to the valve outputs. The various control values of the controller are directly linked to the control value inputs of the valve outputs without external bus communication. In the same way, the valve outputs can receive their control values via communication objects from external room temperature controllers, such as those integrated into sensors or room control units. On the other hand, these room temperature controllers can be used as separate function blocks. In this case, the various control values are linked via communication objects to external thermal drive actuators, motor actuators or fan coil actuators that do not include a controller function.

The thermal drive actuator also detects an overload or short circuit on the valve outputs. An appropriate diagnostic routine is executed. In the event of a total current overflow or overload/short circuit fault of the device, this is reported via the bus.

Thermal drive actuator RL 605D23 is a built-in device for installation in an automation module box AP 118 or room automation box AP 641, which has to be ordered separately. The bus connection of the device uses a bus terminal block. The electronics of the device are supplied via the bus voltage (no additional supply voltage required).

The maintenance-free terminals are for connecting solid and fine-stranded conductors with conductor cross-sections from 0.5 to 2.5 mm² or for connecting multi-stranded conductors with 2.5 mm² conductor cross-sections to the output channels. Stranded and fine-stranded conductors can be plugged into the terminals without ferrules.

Thermal drive actuator RL 605D23 consists of the device (hardware) and the application program (software).

Functions

Factory settings

In the factory settings, the functions control value transfer for a "switching control value (1 bit)" and a "continuous control value (8 bit)" are assigned to the building site function for all channels (outputs).

Building site function

In the factory settings, the building site function enables the control value transfer for a "switching control value (1 bit)" and a "continuous control value (8 bit)" for controlling the thermal actuators via a corresponding bus pushbutton, even if these devices are yet to be commissioned via the Engineering Tool Software (ETS).

Programming mode

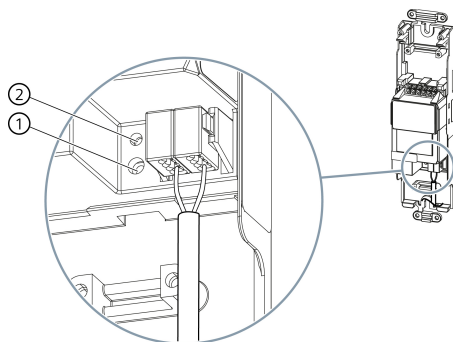

Fig. 1: Programming button and programming LED (exemplary illustration)



After bus voltage recovery, wait several seconds before pushing the programming (1) button (not before booting is complete).

Activating programming mode

- a) Briefly press the programming button (1) (< 2 seconds).
- ⇒ Programming mode is activated.
- ⇒ The programming LED (2) illuminates continuously.

Deactivating programming mode

- ✓ Programming mode is activated. The programming LED (1) lights up continuously.
- a) Briefly press the programming button (1) (< 2 seconds).
- ⇒ Programming mode is deactivated.
- ⇒ The programming LED (2) is not illuminated.

Resetting the device to factory settings

NOTICE	
!	Loss of data due to resetting device! When you reset the device, all parameters and settings entered are deleted. <ul style="list-style-type: none">● Ensure that the device is really supposed to be reset.

A very long push of the programming button (1) of more than 20 seconds resets the device to its factory settings. This is indicated by a uniform flashing of the programming LED for a duration of 8 seconds.

All configuration settings are deleted. The building site function from the factory settings is re-activated.

Behavior on unloading the application program

After unloading the application program with the ETS, the unloaded device has no functions.

Behavior on voltage failure/recovery

The electronics of the device are bus powered. A mains voltage failure therefore only leads to a functional failure of the device if the bus voltage also fails as a result of the mains voltage failure.

In case of bus voltage failure, the current status and other values for each channel are saved permanently so that they can be restored when the bus voltage is recovered.

When bus voltage is recovered, the configured actions for each channel are executed and, depending on the parameters set, new statuses are reported.

For each active override, a starting behavior on bus voltage recovery can be configured (Off, On, Deactivated, Last value).

Setting the valve control direction

De-energized closed or de-energized open thermal actuators can be connected to the thermal drive actuator. The valve control direction is set to take this behavior into account in the further electrical valve control.

Controlling the actuator channels

The actuator channels are controlled via switching commands On/Off (1-bit); the telegrams are converted directly at the output. Continuous positioning commands in percent (1 byte) are converted into a switching control of the thermal actuators via pulse width modulation (PWM) or via limit value evaluation (limit values for opening or closing the valve).

Control value monitoring

If positioning commands are not received within a configurable time, emergency operation with configurable default behavior is activated and an error status is sent. Different continuous default control values (%) in normal operation can be set for summer and winter mode.

Control value limitation for continuous control value (1 byte)

The control value can be limited to maximum and minimum values (%) e.g. for basic temperature control or to increase the service life of the thermal drives.

On the other hand, the valve can always be closed if the control value is smaller than a configurable limit value or the valve can always be opened if the control value is larger than a configurable limit value. Specific valve characteristics are thus taken into account.

Overload and short circuit detection

A diagnostic routine is run for approx. 60 s to identify the overload. The diagnostic routine can also be started via a 1-bit command.

Group-specific evaluation of channels A and B

If the total current exceeds $\sum I > I_{\max}$, the overload for channels A and B can be sent as a 1-bit message.

Excess current/short circuit evaluation per channel

In the event of an excess current/short circuit error ($I > I_{\max}$) on a single channel, the respective overload for the affected channel can be sent as a 1-bit message.

Valve flushing

Valve flushing is used to protect against calcification and seizure of valves that are not used for an extended period of time.

Manual valve flushing

Start (for the set duration)/stop via a 1-bit object

Automatic valve flushing

Cyclically in weeks or demand-oriented if the control value remains below a limit value. Valve flushing is re-activated at a control value of 0%.

Counting of operating hours

An operating hours counter can record the operating hours in hours or seconds at the valve output using various evaluation methods.

On the one hand, the switch-on processes can be counted when electrical voltage is present at the output, or the time for heating or cooling can be recorded, i.e. when the control value exceeds an adjustable threshold value. When an adjustable threshold value is exceeded, a message is sent via the bus.

Counting of switching cycles

Counting of switching cycles records the switching operations on the valve output. If an adjustable threshold value is exceeded, a message is sent via the bus.

Overrides

The thermal drive actuator offers up to 6 override blocks per channel for specific applications. These can be used to configure settings for lock function, forced control, forced position, service mode and user-defined settings. Their effectiveness can be individually set according to priorities.

Room temperature control

The thermal drive actuator contains up to internal room temperature controllers as appropriate for the number of valve outputs. These can be used externally or internally assigned directly to the valve outputs. The various control values of the controller are transferred directly to the control value inputs of the valve outputs without external bus communication. Only a single KNX bus device is used for valve control for single room temperature control.

In addition, the room temperature controllers can be used as separate, independent function blocks in a KNX system. In this case, the various control values are linked via communication objects to external thermal drive actuators, motor actuators or fan coil actuators that do not include a controller function.

Heating or cooling requirements

The heating or cooling requirements are used as a power saving function for a primary system. For heating and cooling requirement requests, the assigned control values of the valve outputs are evaluated. Based on the result, relevant switching inputs to burner and boiler controls are switched according to demand via a KNX switching actuator.

Determination of the largest or a weighted control value

The largest or a weighted control value is determined via the internal calculator. The result can be sent as a 1-byte control value directly to a primary system with an integrated KNX interface. The flow temperature can thus be adapted to the demand from the rooms.

Pump control

The pump control is used for demand-based control of circulating pumps as a power saving function of a primary system. Two controls for circulating pumps are available in the thermal drive actuator. These can be used to separately control a heating cycle and a cooling cycle. In doing so, the assigned control values of the valve outputs are evaluated. Based on the result of the evaluation of the control values, the pumps can be switched based on demand via a KNX switching actuator. In addition, separate fixed position protection prevents the pumps from jamming if they have not been switched on for a longer period of time.

Logic operations

The thermal drive actuator has 6 independent logic blocks with which different mathematical operations are possible: AND, OR, XOR, TRIGGER, LOCK.

The inputs can be linked internally in the device with the status output of the valve control values of a channel or with any KNX communication objects, including external devices. The logic result is sent via a KNX communication object. The data types of the logic inputs and outputs can be selected freely.

Diagnostic routine

Each channel of the thermal drive actuator detects an overload or a short circuit on the valve outputs. To do this, a diagnostic routine which takes approx. 60 s is executed on both channel outputs.

The diagnostic routine can be started in two different ways:

- Automatic start when a fault is detected (overload).
- When sending a start telegram via the communication object ("").

Short circuit/overload per channel on the device

NOTICE	
	<p>Damage to the device due to improper operation in the event of a permanent short circuit on the channel</p> <p>The device may be damaged if the diagnostic routine is started repeatedly when a short circuit is permanently present.</p> <ul style="list-style-type: none">• Before starting the diagnostic routine, the short circuit fault must be resolved.

An overload/short circuit fault on an individual channel output can be reported via the bus.

Overload on the device

In the event of a total current overload on the device, the overload can be reported via the bus.

Schematic design of a thermal drive actuator channel

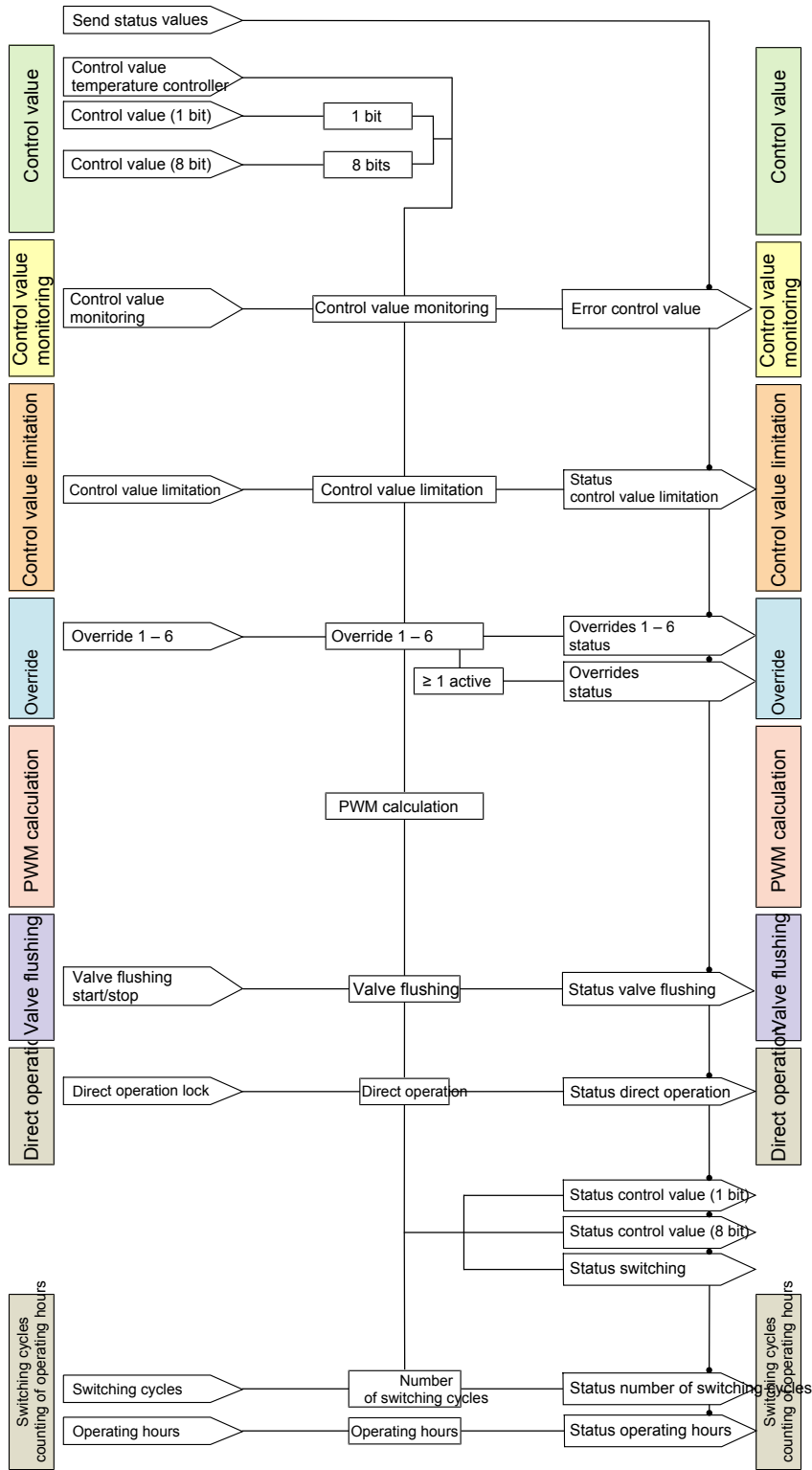

Position and function of the connections, operating and display elements

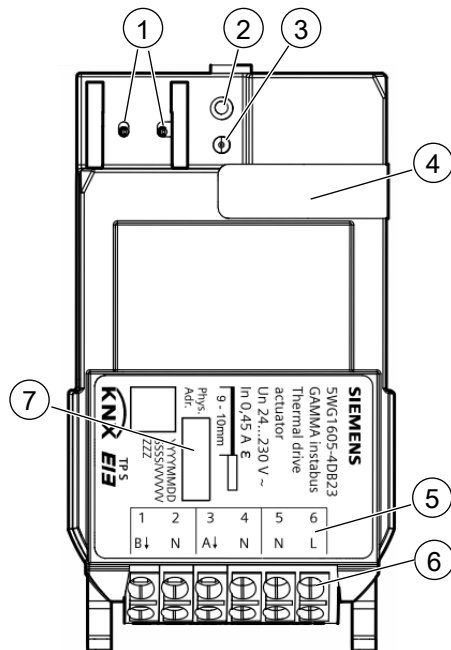



Fig. 2: Position and function of the connections and labeling, operating and display elements

Pos.	Connection, operating or display element	Function
1	Connection pins for KNX bus terminal block	Connect KNX bus.
2	Programming button	Short push of button (< 2 s):
3	Programming LED (red)	<ul style="list-style-type: none"> Activate programming mode, display status (programming LED on = active) Very long push of button (> 20 s): <ul style="list-style-type: none"> Reset to factory settings (programming LED starts flashing after 20 s)
4	Label with barcode of the device	Two copies of the barcode are printed on it. The second barcode can be separated to facilitate commissioning and, for example, be kept with the documents for the project.
5	Labeling of the connection terminals	
6	Connection terminals	Connect input and loads.
7	Label field	Enter the physical address.

Type overview

Type	Designation	Item number	KNX PL-Link
	Thermal drive actuator RL 605D23, 2 x AC 24...230V		yes

Scope of delivery

Module for installation in AP 118 automation module box or in AP 641 room automation module box.

Version of the Engineering Tool Software

Application	Version
Engineering Tool Software (ETS)	ETS 5 or above

Accessories



Type	Order number	Designation
	5WG1118-4AB01	Automation module box AP 118
	5WG1641-3AB01	Room automation module box AP 641

Table 1: Automation module box AP 118 and room automation module box AP 641

Product documentation

Documents related the product, such as operating and installation instructions, application program description, product database, additional software and CE declarations can be downloaded from the following website:

<http://www.siemens.com/gamma-td>



Frequently asked questions

For frequently asked questions about the product and their solutions, see:

<https://support.industry.siemens.com/cs/products?dtp=Faq&mf=ps&lc=de-WW>



Support

Contact details for additional questions relating to the product:

Tel.: +49 89 9221-8000

<http://www.siemens.com/supportrequest>



Security

The device is designed to be installed in an AP 118 automation module box or in an AP 641 room automation box.

⚠ CAUTION



National safety regulations

Failure to comply with national safety regulations may result in personal injury and property damage.

- Observe national provisions and comply with the appropriate safety regulations.

⚠ WARNING



Risk of death due to electric voltage and electric current!

Electrical expertise is required for the installation. Incorrect installation can deactivate electrical safety features without this being apparent to a lay person.

- Do not open the casing of the device.
- The device should only be installed and put into operation by a certified electrician.
- Overload/short-circuit faults may only be rectified by qualified electricians with the AC voltage switched off.
- Secure each phase with a B16 line protection switch.
- Only use conventional transformers that comply with the relevant standards and contain a thermal fuse.

⚠ WARNING



Danger due to electrical voltage

The device is not suitable for disconnecting.

Voltage may be present at the outputs even when the device is switched off. When working on the connected consumers, always disconnect the device from the power supply via the upstream fuse.

NOTICE



Behavior in the event of a fault

- ▷ The actuators of a channel output do not switch.
- Determine the cause of the overload shutdown.
- Switch off the power supply.
- Resolve the short circuit/overload and replace defective actuators.
- Check and, if appropriate, reduce the number of connected actuators.
- Switch on the power supply of the device again.

Connecting thermal actuators to the semiconductor outputs



Areas of use

The device is installed in an automation module box AP 118 or a room automation module box AP 641 in dry interior spaces.

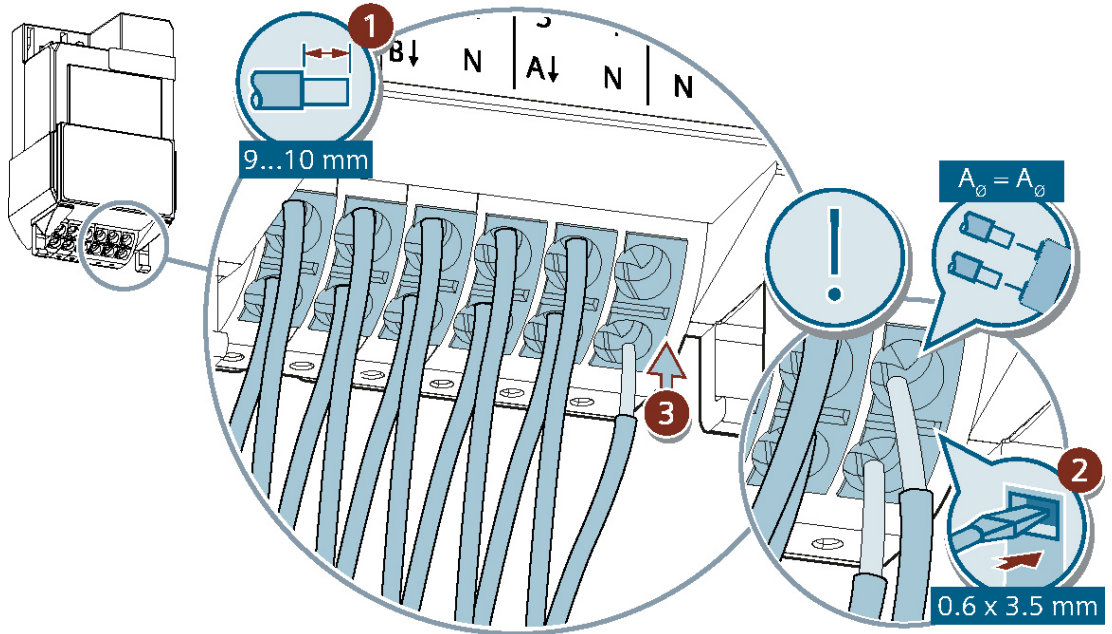
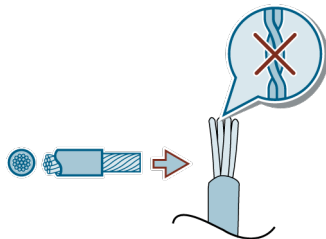

Fig. 3:

Cu	
	0.5...2.5 mm ²
	2.5 mm ²



Connecting KNX

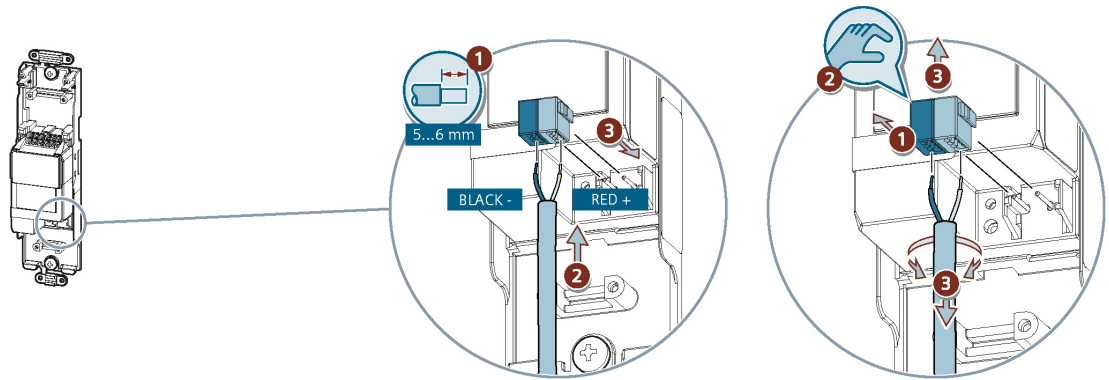

Fig. 4:

Cu	
	0.6...0.8 mm

Test of KNX 24 V DC type SELV

This test can be used to check whether the bus connection cable is connected with the correct polarity and whether device is supplied with bus voltage.

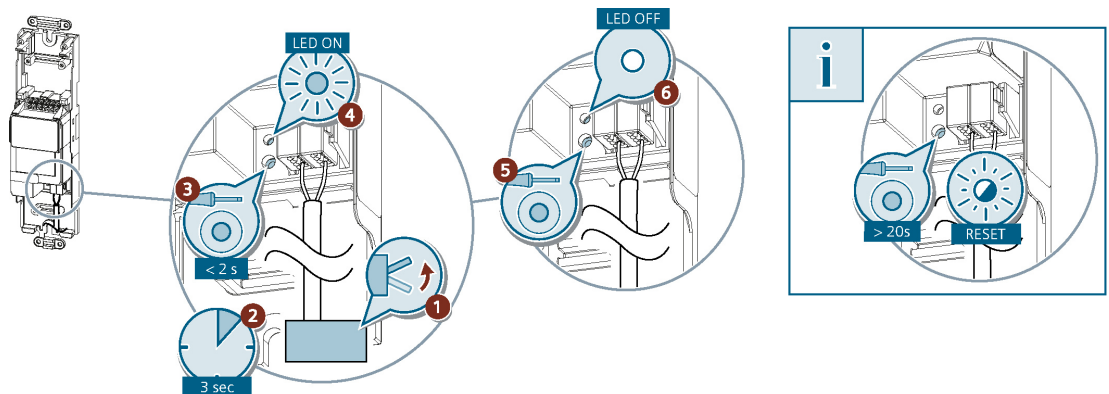

Fig. 5:

A very long push of the programming button of more than 20 seconds resets the device to its factory settings.

Disposal

	<p>The device is considered an electronic device for disposal in accordance with European Directive and may not be disposed of as domestic waste.</p> <ul style="list-style-type: none"> • Use only designated channels for disposing the devices. • Comply with all local and currently applicable laws and regulations.
--	---



If a device is defective, contact the local sales office.

Power supply	
KNX bus voltage	DC 24 V (DC 21...30 V)
KNX power consumption	10 mA
KNX power loss (power consumption)	0.24 W

Outputs (semiconductor switch)	
Number of outputs	2
Switching voltage	AC 24V... 230V (50 - 60 Hz)
Output current	
Rated current per channel* ¹	0.45 A
max. inrush current (2 s)* ¹	2.75 A
max. inrush current (2 min)* ¹	0.75 A

Actuators	
Number of actuators per channel or device 24 V	2* ²
Number of actuators per channel or device 230 V	5* ³

*¹ per channel and device

*² for e.g. max. 375 mA for max. 2 min

*³ for e.g. max. 550 mA for max. 2 s

Power loss	
Maximum power loss of the device at rated output	0.84 W

Mechanical data	
Housing material	Plastic
Dimensions	See Dimension drawing [► 16]
Product weight	47 g
Fire load	1 MJ

Environmental conditions	
Ambient temperature in operation	-5 °C...+45 °C (23 °F...113 °F)
Storage temperature	-20 °C...+70 °C (-4 °F...158 °F)
Transport temperature	-25 °C...+70 °C (-13 °F...158 °F)
Relative humidity (non-condensing)	5 %...95 %
Environmental rating	EN 60721-3-3 class 3k5

Protection settings	
Degree of pollution (according to IEC 60664-1)	2
Over-voltage category (according to IEC 60664-1)	III
Housing protection class (according to EN 60529)	IP20 (when installed AP 118 / AP 641)

Protection settings	
Electrical safety, bus (SELV)	yes
Electrical safety, device fulfills	EN 50428
EMC requirements, device complies with	EN 50428
Test mark	KNX, EAC, RCM, WEEE, China-RoHS
CE mark	yes

Reliability	
Failure rate (at 40°C)	227 fit

Connection example

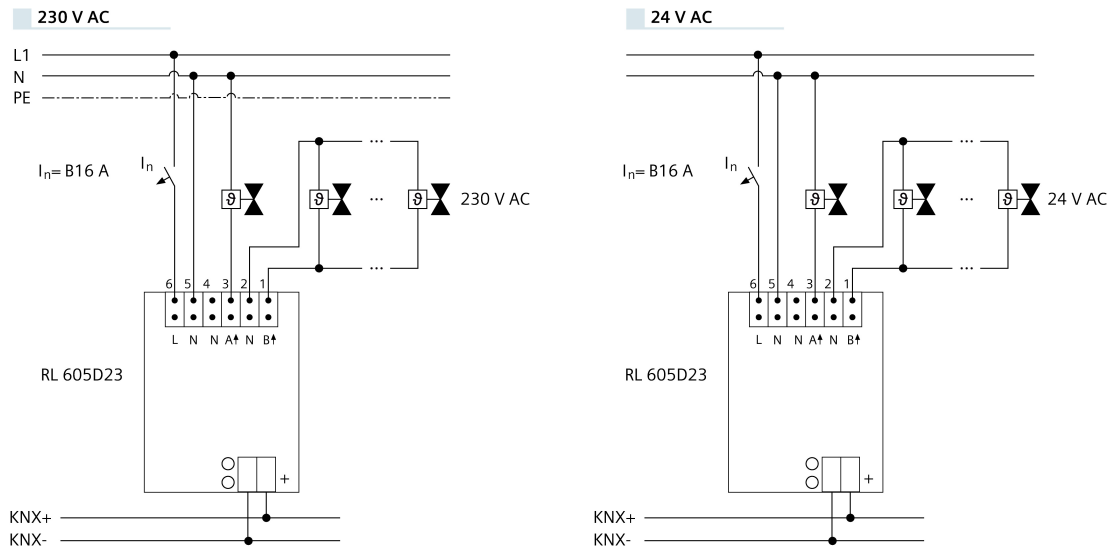

Fig. 6:

⚠ CAUTION



A common supply voltage for all channels is applied to terminals L1 and N.
 Each output channel has its own ground terminal.
 The neutral conductors of the actuators can be connected either directly to the ground terminal on the device or alternatively together via a suitable ground potential.
 The neutral conductors of the outputs may only be used for connecting the electro-thermal actuators.

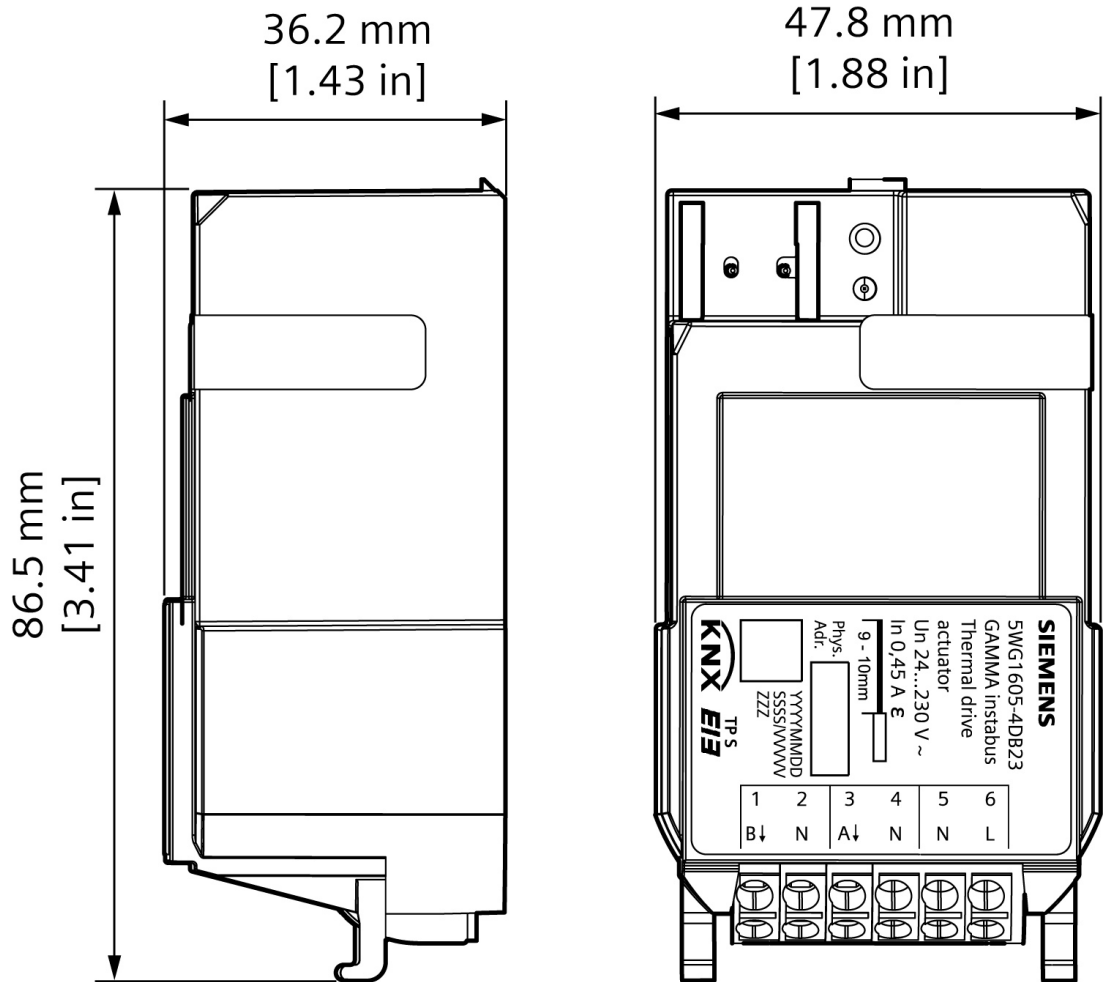

Fig. 7:

Compliance information

FCC Statement

⚠ WARNING	
	<p>Installation and usage of equipment not in accordance with instructions manual may result in:</p> <p>Radiation of radio frequency energy Interference to radio communications</p> <ul style="list-style-type: none"> • Install and use equipment in accordance with installation instructions manual • Read the following information

This equipment generates, uses, and can radiate radio frequency energy and if not installed and used in accordance with the instructions manual, may cause interference to radio communications.

It has been tested and found to comply with the limits for a Class A computing device pursuant to Part 15 of FCC Rules, which are designed to provide reasonable protection against such interference when operated in a commercial environment.

Operation of this equipment in a residential area is likely to cause interference in which case the user at his own expense will be required to take whatever measures may be required to correct the interference.

FCC Statement

This equipment has been tested and found to comply with the limits for a Class B digital device, pursuant to part 15 of the FCC Rules. These limits are designed to provide reasonable protection against harmful interference in a residential installation. This equipment generates, uses and can radiate radio frequency energy and, if not installed and used in accordance with the instructions, may cause harmful interference to radio communications. However, there is no guarantee that interference will not occur in a particular installation. If this equipment does cause harmful interference to radio or television reception, which can be determined by turning the equipment off and on, the user is encouraged to try to correct the interference by one or more of the following measures:

- Reorient or relocate the receiving antenna.
- Increase the separation between the equipment and receiver.
- Connect the equipment into an outlet on a circuit different from that to which the receiver is connected.
- Consult the dealer or an experienced radio/TV technician for help.

This device complies with Part 15 of the FCC rules. Operation is subject to the following two conditions:

1. This device may not cause harmful interference, and
2. this device must accept any interference received, including interference that may cause undesired operation

FCC Caution: Changes or modifications not expressly approved by Siemens Switzerland Ltd. could void the user's authority to operate the equipment. United States representative <https://new.siemens.com/us/en/products/buildingtechnologies/home.html>

Industry Canada statement

This device complies with ISED's license-exempt RSSs. Operation is subject to the following two conditions:

1. This device may not cause interference, and
2. This device must accept any interference received, including interference that may cause undesired operation.

Issued by
Siemens Switzerland Ltd
Smart Infrastructure
Global Headquarters
Theilerstrasse 1a
CH-6300 Zug
+41 58 724 2424
www.siemens.com/buildingtechnologies

© Siemens Switzerland Ltd, 2023
Technical specifications and availability subject to change without notice.

Document ID A6V13488292_en--_b
Edition 2023-04-06